

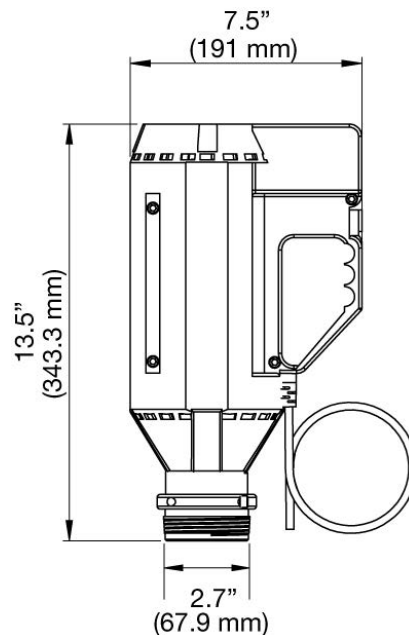

Technical Specifications

Enclosure:	Explosion Proof (IP54)
Available Voltage:	SP-410EX : 110V
.....	SP-420EX : 220V
Horsepower (Watts):	SP-410EX : 0.3 (230)
.....	SP-420EX : 0.8 (600)
Phase:	1
Amps:	2 - 2.6 (varies by voltage)
Frequency:	50-60 Hz
Certification:	SP-410EX : CSA Class I, Div. I, Group D, Insulation Class B, Temp Code T3C
.....	SP-420EX : Atex II 2G Ex d IIA T4
Housing Material:	Aluminum (Inner Housing) / Nylon (Outer Shell)
Power Cord Length:	12 ft. (3,7 m)
Power Cord Plug:	Not Provided
Noise Level:	80 dBa
Thermal Overload:	No
Variable Speed:	No
Weight:	17 lbs (7,7 kg)

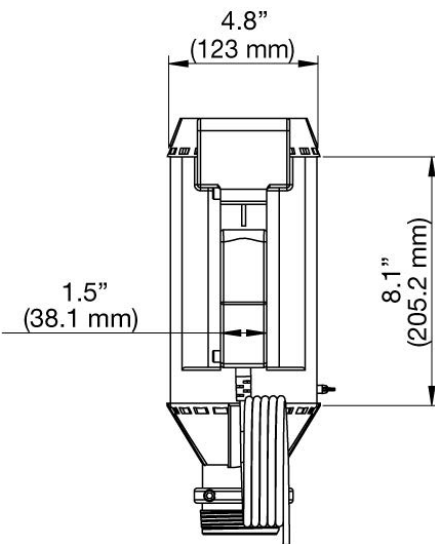

NOTE: Explosion proof motor regulations require that motors be returned to the manufacturer for repair.

WARNING: Pumping of flammables or combustible liquids can generate a static electric discharge, causing fire or explosion resulting in injury or death. Read and understand operating instructions before starting this unit. Follow all federal, state and local safety codes including NFPA 30 - NFPA77. Prior to connecting to air supply, install bond and ground wires and check continuity of each wire. A meter reading of one ohm or less is required for safe liquid transfer. Use only metallic drum, receiving vessel and metallic pump when pumping flammables. Air motors are not recognized under any current Underwriter's Laboratory listing program. Consult a qualified engineer for suitability for use in a hazardous area or on flammables.